

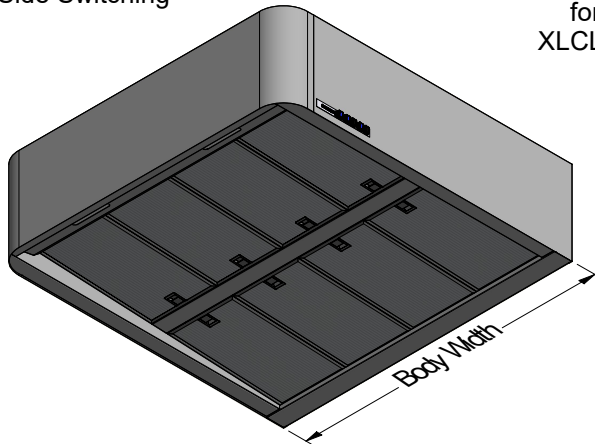

PLEASE CONTACT YOUR LOCAL QASAIR RETAILER FOR DUCTING.
XL CLIFTON MODELS COMES TOP DUCTED AND CAN BE CONVERTED TO BACK DUCTING ON SITE BY THE INSTALLER.

Side Switching



Power entry location for standard XLCLI models.

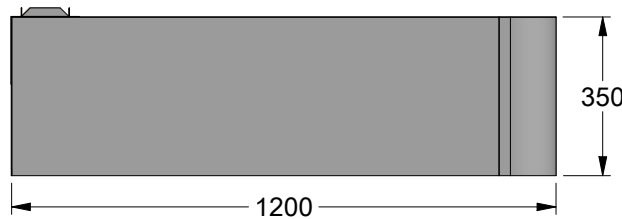
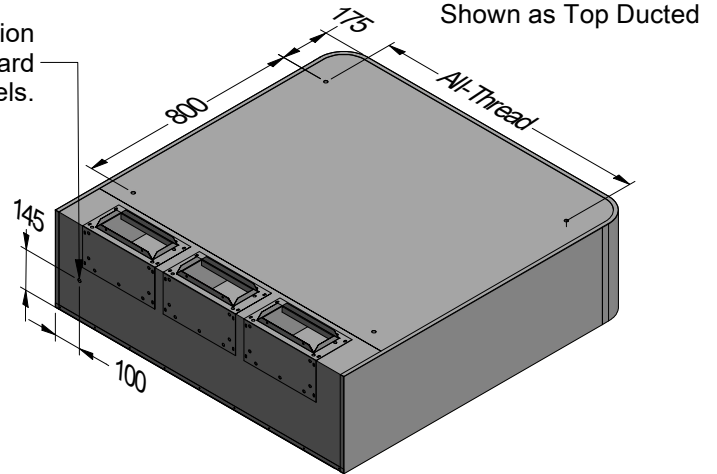

Remotely Switched

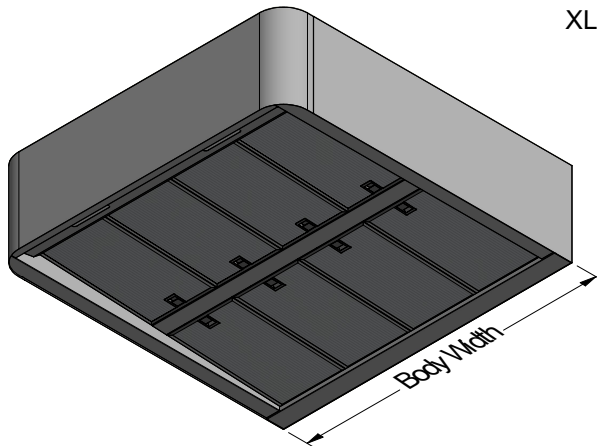

Power entry location for remotely switched XLCLI models.

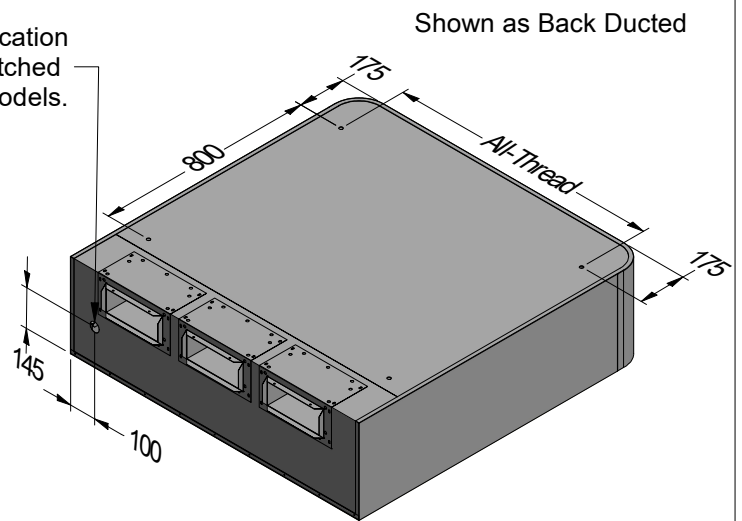

PLEASE NOTE "R" AT THE END OF THE MODEL No. DENOTES REMOTELY SWITCHED
FOR REMOTELY SWITCHED MODELS SWITCHING IS NOT SUPPLIED
ELECTRICAL CONNECTION IS MADE AT JUNCTION BOX INSIDE RANGEHOOD

Model	XLCLI 1200L-3 XLCLI 1200L-3 R	XLCLI 1500L-3 XLCLI 1500L-3 R	Model	XLCLI 1200L-3 XLCLI 1200L-3 R	XLCLI 1500L-3 XLCLI 1500L-3 R
Body Width	1200mm	1500mm	Filter Size	272mm x 480mm	272mm x 480mm
Motor Box / Flue Width	N/A	N/A	Conversion Top/Back Back/Top	YES	YES
Motor Qty	3	3	Electrical Connection	Junction Box	Junction Box
LED Light	Cool	Cool	Minimum Height (H =)	N/A	N/A
Nightlight	NO	NO	Maximum Height (H =)	N/A	N/A
Light Qty	2	3	Coating Available	N/A	N/A
Light Centres	545mm	459mm	All-thread Fixing Centres	1000mm	1300mm
Filter Qty	8	10	Corner Type	Round	Round
ACWMLR			Condari Pty Ltd.	Version: A 13/09/2023F	Page 1 of 1