

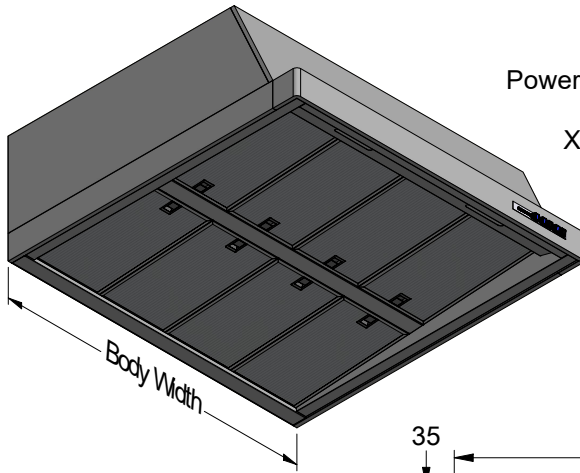

XL BALTIMORE COMES TOP DUCTED AND CAN BE CONVERTED TO BACK DUCTED ON SITE BY THE INSTALLER.

Top Ducted shown with optional shroud



Power entry location for standard XLBAL models.

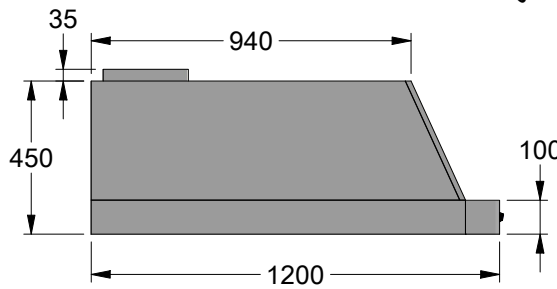
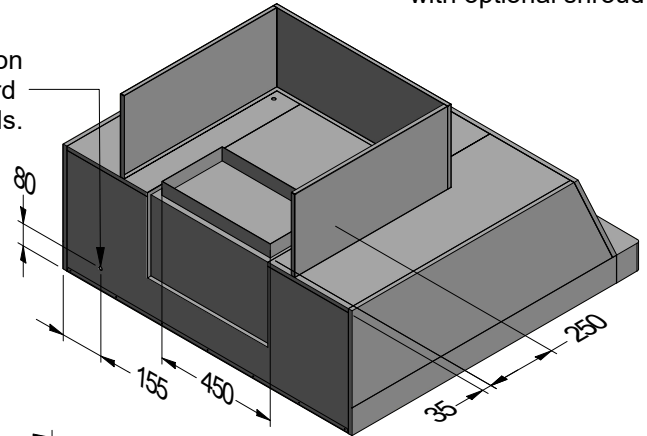

Back Ducted Remotely Switched

All-Thread support shown in position

Remotely Switched Back Ducted shown with optional shroud

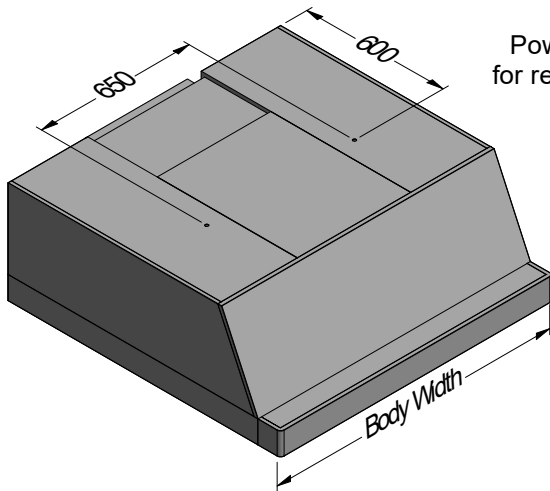

Power entry location for remotely switched XLBAL models.

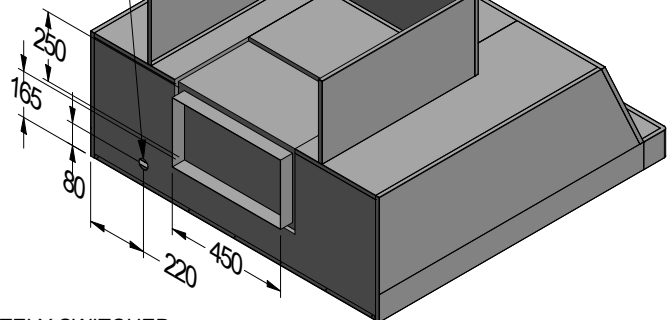

PLEASE NOTE "R" AT THE END OF THE MODEL No. DENOTES REMOTELY SWITCHED FOR REMOTELY SWITCHED MODELS SWITCHING IS NOT SUPPLIED ELECTRICAL CONNECTION IS MADE AT JUNCTION BOX INSIDE RANGEHOOD

Model	XLBAL 1200L-3 XLBAL 1200L-3 R	XLBAL 1500L-3 XLBAL 1500L-3 R	Model	XLBAL 1200L-3 XLBAL 1200L-3 R	XLBAL 1500L-3 XLBAL 1500L-3 R
Body Width	1200mm	1500mm	Filter Size	272mm x 480mm	272mm x 480mm
Motor Box / Flue Width	N/A	N/A	Conversion Top/Back Back/Top	YES	YES
Motor Qty	3	3	Electrical Connection	Junction Box	Junction Box
LED Light	Cool	Cool	Minimum Height (H =)	N/A	N/A
Nightlight	NO	NO	Maximum Height (H =)	N/A	N/A
Light Qty	2	3	Coating Available	N/A	N/A
Light Centres	545mm	459mm	All-thread Fixing Centres	650	650
Filter Qty	8	10	Corner Type	Round	Round
ACWMLR			Condari Pty Ltd.	Version: A 13/09/2023F	Page 1 of 1